

**Agilent 16093B Test Fixture**

# **Operating Note**

**Second Edition**



**Agilent Technologies**

**Agilent Part No. 16093-90011**

**May 2000**

Printed in Japan

---

## Notices

The information contained in this document is subject to change without notice.

This document contains proprietary information that is protected by copyright. All rights are reserved. No part of this document may be photocopied, reproduced, or translated to another language without the prior written consent of the Agilent Technologies.

Agilent Technologies Japan, Ltd.

Component Test PGU-Kobe

1-3-2, Murotani, Nishi-Ku, Kobe-shi, Hyogo, 651-2241 Japan

Copyright © Agilent Technologies Japan, Ltd. 1986, 2000

---

## Manual Printing History

The manual's printing date and part number indicate its current edition. The printing date changes when a new edition is printed. (Minor corrections and updates that are incorporated at reprint do not cause the date to change.) The manual part number changes when extensive technical changes are incorporated.

August 1986      First Edition (part number : 16093-90011)

May 2000        Second Edition (part number : 16093-90011)

---

## Safety Summary

The following general safety precautions must be observed during all phases of operation, service, and repair of this instrument. Failure to comply with these precautions or with specific WARNINGS elsewhere in this manual may impair the protection provided by the equipment. In addition it violates safety standards of design, manufacture, and intended use of the instrument.

Agilent Technologies assumes no liability for the customer's failure to comply with these requirements.

- **Ground The Instrument**

To avoid electric shock hazard, the instrument chassis and cabinet must be connected to a safety earth ground by the supplied power cable with earth blade.

- **DO NOT Operate In An Explosive Atmosphere**

Do not operate the instrument in the presence of flammable gasses or fumes. Operation of any electrical instrument in such an environment constitutes a definite safety hazard.

- **Keep Away From Live Circuits**

Operating personnel must not remove instrument covers. Component replacement and internal adjustments must be made by qualified maintenance personnel. Do not replace components with the power cable connected. Under certain conditions, dangerous voltages may exist even with the power cable removed. To avoid injuries, always disconnect power and discharge circuits before touching them.

- DO NOT Service Or Adjust Alone

Do not attempt internal service or adjustment unless another person, capable of rendering first aid and resuscitation, is present.

- DO NOT Substitute Parts Or Modify Instrument

Because of the danger of introducing additional hazards, do not install substitute parts or perform unauthorized modifications to the instrument. Return the instrument to a Agilent Technologies Sales and Service Office for service and repair to ensure that safety features are maintained.

- Dangerous Procedure Warnings

Warnings, such as the example below, precede potentially dangerous procedures throughout this manual. Instructions contained in the warnings must be followed.

---

**WARNING**

---

**Dangerous voltages, capable of causing death, are presenting this instrument. Use extreme caution when handling, testing, and adjusting this instrument.**

---

## Certification

Agilent Technologies certifies that this product met its published specifications at the time of shipment from the factory. Agilent Technologies further certifies that its calibration measurements are traceable to the United States National Institute of Standards and Technology, to the extent allowed by the Institution's calibration facility, or to the calibration facilities of other International Standards Organization members.

---

## Warranty

This Agilent Technologies instrument product is warranted against defects in material and workmanship for a period corresponding to the individual warranty periods of its component products. Instruments are warranted for a period of one year. Fixtures and adapters are warranted for a period of 90 days. During the warranty period, Agilent Technologies Company will, at its option, either repair or replace products that prove to be defective.

For warranty service or repair, this product must be returned to a service facility designated by Agilent Technologies. Buyer shall prepay shipping charges to Agilent Technologies and Agilent Technologies shall pay shipping charges to return the product to Buyer. However, Buyer shall pay all shipping charges, duties, and taxes for products returned to Agilent Technologies from another country.

Agilent Technologies warrants that its software and firmware designated by Agilent Technologies for use with an instrument will execute its programming instruction when properly installed on that instrument. Agilent Technologies does not warrant that the operation of the instrument, or software, or firmware will be uninterrupted or error free.

---

## **Limitation of Warranty**

The foregoing warranty shall not apply to defects resulting from improper or inadequate maintenance by Buyer, Buyer-supplied software or interfacing, unauthorized modification or misuse, operation outside the environmental specifications for the product, or improper site preparation or maintenance.

---

### **IMPORTANT**

No other warranty is expressed or implied. Agilent Technologies specifically disclaims the implied warranties of merchantability and fitness for a particular purpose.

---

## **Exclusive Remedies**

The remedies provided herein are buyer's sole and exclusive remedies. Agilent Technologies shall not be liable for any direct, indirect, special, incidental, or consequential damages, whether based on contract, tort, or any other legal theory.

---

## **Assistance**

Product maintenance agreements and other customer assistance agreements are available for Agilent Technologies products.

For any assistance, contact your nearest Agilent Technologies Sales and Service Office.

Addresses are provided at the back of this manual.

**Agilent 16093B  
TEST FIXTURE**

**MANUAL IDENTIFICATION**

Model Number: 16093B
Date Printed: May 2000
Part Number: 16093-90011

**Operating Note**

This supplement contains information for correcting manual errors and for adapting the manual to newer instruments that contains improvements or modifications not documented in the existing manual.

To use this supplement

1. Make all ERRATA corrections
2. Make all appropriate serial-number-related changes listed below

SERIAL PREFIX OR NUMBER CHANGES	MAKE MANUAL
All	1

◆ New Item

SERIAL PREFIX OR NUMBER CHANGES	MAKE MANUAL

**ERRATA**

**CHANGES 1**

CHANGE 1 contains the information needed to adapt the 16093B's manual.

**Page 2, DESCRIPTION.**

Change the 'Maximum applied dc bias voltage:' as follows.

Maximum Voltage:            ±40V peak max. (AC + DC)

**NOTE**

Manual change supplement are revised as often as necessary to keep manuals as current and accurate as possible. Agilent Technologies recommends that you periodically request the latest edition of this supplement. Free copies are available from all Agilent Technologies offices. When requesting copies, quote the manual identification information from your supplement, or the model number and print date from the title page of the manual.

## 1. INTRODUCTION.

This operating note provides the information required to maintain and repair the Hewlett-Packard Model 16093B Binding Post Fixture. The Model 16093B, pictorially shown on the front cover, was specially designed for use with the Model 4191A RF Impedance Analyzer. How to use the 16093B performance characteristic data and operating instructions are given in the 4191A's Operation and Service Manual. To order additional copies of this operating note, use the part number listed on the rear cover and contact the nearest Hewlett-Packard Office.

## 2. MAINTENANCE.

### 2-1 PERIODIC AND PREVENTIVE MAINTENANCE OF THE APC-7 CONNECTOR CONTACTS.

Keep contact surface of the APC-7 connector (part of the test fixture) clean and dry. Replace the center pin of the APC-7 connector every 50 connections and disconnections or when the center pin is damaged or worn. The appropriate procedure and the precautions to follow when cleaning and replacing the contacts of the APC-7 connector are outlined in paragraphs 3 and 4.

### 2-2 PARTS REPLACEMENT.

Figure 1 lists all replaceable parts of the 16093B. To identify the locations of the individual parts listed, refer to the exploded view. Do not disassemble any further than shown in the figure.

To order the necessary replacement parts, identify them by their Hewlett-Packard part number. If a defective part is located in an assembly that cannot be disassembled, order the next higher assembly or return the whole device to the nearest Hewlett-Packard Sales/Service Office for repair or replacement. A list of the Sales/Service Offices is given inside the rear cover.

## 3. REPLACEMENT OF THE APC-7 CONNECTOR CONTACT.

To maintain optimum contact between the APC-7 connector contacts, it is recommended that the RF Connector Contact (HP Part No. 1250-0907) of the center conductor be replaced every 50 connections/disconnections or as required (when damaged or worn). The 11591A APC-7 Pin Replacement Kit is required to remove the contact from the connector. The replacement procedure is outlined below:

- (1) Grip the Pin Vise, and fully open the vise chuck by pressing the button on the vise.
- (2) Place the Pin Vise over the center conductor of the APC-7 connector and guide pin into the hole of the contact.
- (3) Close the vise chuck by releasing the button; the chuck will close around the connector contact and extract it from the APC-7 connector.
- (4) Lift the Pin Vise up and away, and remove the extracted contact from the vise chuck.
- (5) Carefully insert the new contact into the center conductor using tweezers. Push the contact into the center conductor with a clean flat-head stick until it is seated.

#### 4. CLEANING APC-7 CONNECTORS.

The APC-7 connector contact surface of the UNKNOWN terminal, terminations and test fixtures must be kept clean, i.e., free of dust, oil or any foreign matter which will prevent good contact. To maintain clean contact surfaces, it is recommended that the operator perform periodic cleaning as necessary. Use a lint-free cloth and, if a cleaning fluid is needed, use isopropyl alcohol.

#### CAUTION

Do not use aromatic or chlorinated hydrocarbons, esters, ethers, terpenes, higher alcohols, ketones, or such chemicals as benzene, toluene, turpentine, dioxane, gasoline, cellulose acetate, or carbon tetrachloride. Keep exposure of the connector parts to both the cleaning fluid and its vapors as brief as possible.

#### 5. DESCRIPTION.

The 16093B Binding Post Fixture is used for general measurement of both axial and radial lead components. Three binding post terminals are located on the terminal deck as shown below:

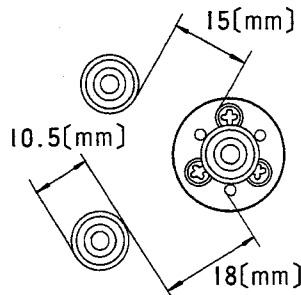

Usable frequency range: DC to 125MHz.  
Electrical length: 0.34cm (typ.).  
Maximum applied dc bias voltage:  $\pm 40V$ .

#### Note

A special skirted grounding terminator is furnished with the 16093B Binding Post Fixture. The terminator provides an optimum shorting configuration between the High terminal and ground of the test fixture. When the test fixture is short-circuited, the residual resistance and inductance of the fixture terminal can be measured in the L-R (inductance - series resistance) mode of the 4191A using the following procedure:

Remove the post of the High terminal from the test fixture deck. Attach the special grounding electrode, with its concave slide down, to test fixture positive contact post with the post removed. Under this condition, the residual inductance and resistance are displayed on DISPLAY A and DISPLAY B, respectively.

When reassembling the APC-7 type RF connectors mounted on the 16093B after replacing a damaged or worn part, the center conductor must be precisely centered in reference to the ground screw. To ensure proper centering, a tube-shaped spacer with an outer diameter of 6.95mm and inner diameter of 5.05mm must be used. To obtain the spacer, contact the nearest Hewlett-Packard office.

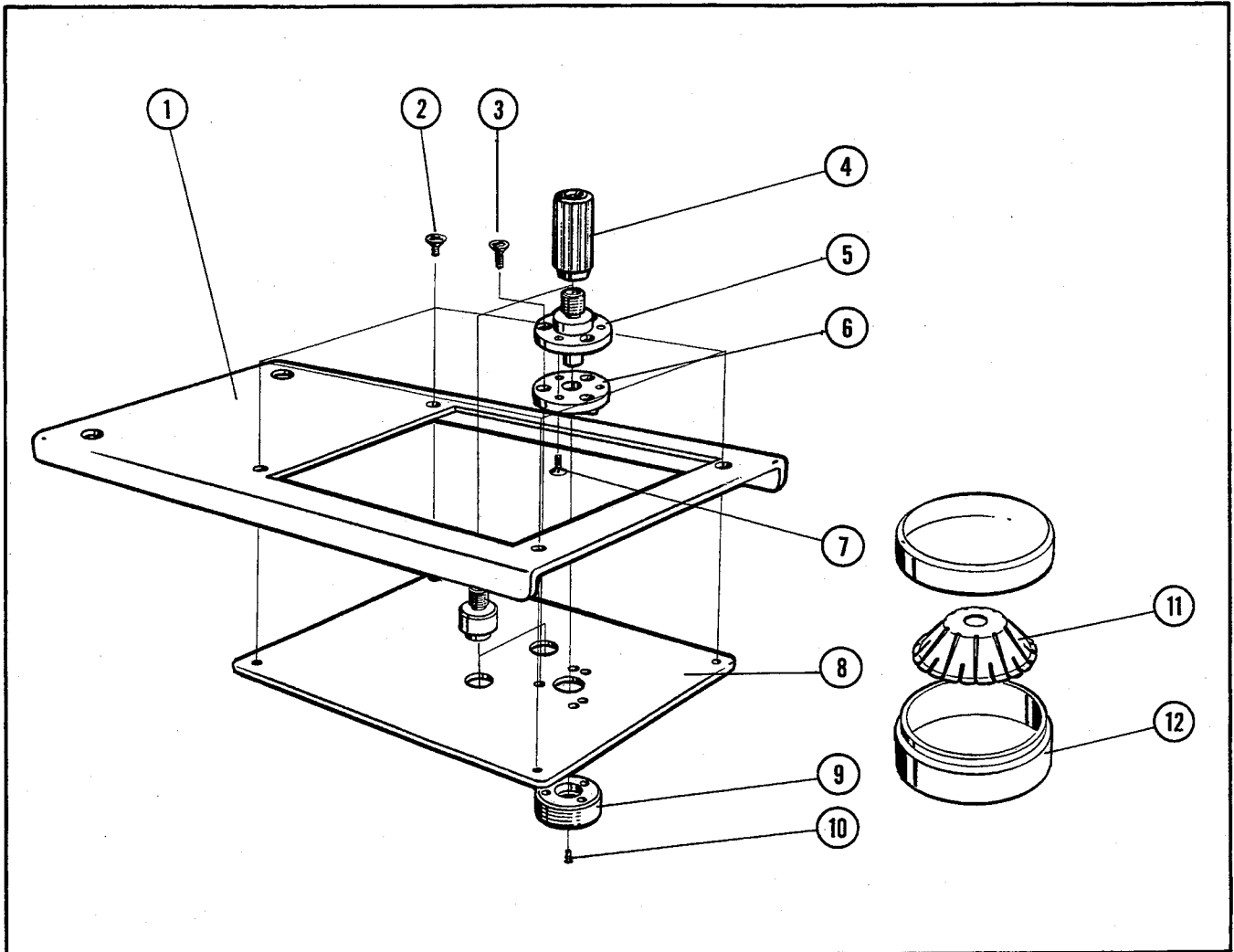

Reference	HP Part No.	Qty	Description
1	16093-00211	1	TABLE
2	0520-0163	4	SCREW
3	0520-0126	3	SCREW
4	04342-3259	3	KNOB
5	16093-29010	1	CENTER CONDUCTOR
6	16093-40010	1	FLANGE
7	0520-0126	3	SCREW
8	16093-65003	1	PEDESTAL PLATE
9	16093-24010	1	GROUND SCREW
10	1250-0907	1	CONTACT-RF CONNECTOR
11	16093-08010	1	GROUND SPRING
12	1540-0622	1	CASE

Figure 1. Parts Identification for 16093B.



## REGIONAL SALES AND SUPPORT OFFICES

*For more information about Agilent Technologies test and measurement products, applications, services, and for a current sales office listing, visit our web site: <http://www.agilent.com/find/tmdir>. You can also contact one of the following centers and ask for a test and measurement sales representative.*

*11/29/99*

### **United States:**

Agilent Technologies  
Test and Measurement Call Center  
P.O.Box 4026  
Englewood, CO 80155-4026  
(tel) 1 800 452 4844

347 Burwood Highway  
Forest Hill, Victoria 3131  
(tel) 1-800 629 485 (Australia)  
(fax) (61 3) 9272 0749  
(tel) 0 800 738 378 (New Zealand)  
(fax) (64 4) 802 6881

### **Canada:**

Agilent Technologies Canada Inc.  
5150 Spectrum Way  
Mississauga, Ontario  
L4W 5G1  
(tel) 1 877 894 4414

### **Asia Pacific:**

Agilent Technologies  
24/F, Cityplaza One, 1111 King's Road,  
Taikoo Shing, Hong Kong  
(tel) (852)-3197-7777  
(fax) (852)-2506-9284

### **Europe:**

Agilent Technologies  
Test & Measurement  
European Marketing Organization  
P.O.Box 999  
1180 AZ Amstelveen  
The Netherlands  
(tel) (31 20) 547 9999

### **Japan:**

Agilent Technologies Japan Ltd.  
Call Center  
9-1, Takakura-Cho, Hachioji-Shi,  
Tokyo 192-8510, Japan  
(tel) (81) 426 56 7832  
(fax) (81) 426 56 7840

### **Latin America:**

Agilent Technologies  
Latin American Region Headquarters  
5200 Blue Lagoon Drive, Suite #950  
Miami, Florida 33126  
U.S.A.  
(tel) (305) 267 4245  
(fax) (305) 267 4286

### **Australia/New Zealand:**

Agilent Technologies Australia Pty Ltd

Customer Order Number

16093-90011

Printed in Japan

Manufacturing Part Number

**16093-90011**

